

# WAJADTUHA Interactive Flat Panel Specification-Mode GSTL-C6 CVT.V100



## Product Features

- With 4K UHD display, supporting full-channel 4K UI display
- Built-in 8 Cores CPU, faster and more efficient processing speed
- Zero-bonding technology, 3.2mm anti-glare tempered glass with high haze OC
- ±2mm high precision infrared touch, smooth writing
- Supports two-pen writing at the same time and two-colors display, making it easier for multiple people to collaborate
- The default front port supports 3\*USB3.0 (Android+Windows)+ TYPE-C+TOUCH OUT+HDMI IN
- Smart sidebar menu.
- Support built-in 13MP/48MP Camera+8 Array MIC (Optional)
- With HDMI-OUT, Back Type-C

## Display Parameter

Model Num	GSTL-X9-65S	GSTL-X9-75S	GSTL-X9-86S
Size	65inch	75inch	86inch
Backlight Type	D-LED	D-LED	D-LED
Panel Brand	CSOT/BOE	CSOT/BOE	CSOT/BOE
Resolution(pixels)	3840x2160	3840x2160	3840x2160
Brightness	≥300cd/m2(typ.)	≥300cd/m2(typ.)	≥300cd/m2(typ.)
Aspect Ratio	16:9	16:9	16:9
Contrast Ratio	1200:1/4000:1	1200:1/4000:1	1200:1/4000:1
Response Time	8ms (typ.)	8ms (typ.)	8ms (typ.)
Pixel Pitch (mm)	0.372(H)x0.372(V)	0.4298(H)x0.4298(V)	0.4875(H)x0.4875(V)
Refreshing Frequency	60Hz	60Hz	60Hz
Viewing Angle	178°(H)/178°(V)	178°(H)/178°(V)	178°(H)/178°(V)
Life Time	≥50,000 Hrs(min.)	≥50,000 Hrs(min.)	50,000 Hrs(min.)
View Area (mm)	1428.48(H)x803.52(V)	1649.66(H)x927.94(V)	1895.04(H)x1065.96(V)
Color Gamut (X% NTSC)	72%(NTSC)	72%(NTSC)	72%(NTSC)
Colorfulness	1.07B(10 bit)	1.07B(10 bit)	1.07B(10 bit)

## System

Chipset	GK6780	
CPU Architecture	Octa-core A55	
CPU Working Frequency	1.2GHz	
GPU	Mali G52MC2 600MHz	
RAM	Standard: 4GB	Optional: 8GB
ROM	Standard: 32GB	Optional: 64GB/128GB
OS	Android 12.0	
Power Requirements	AC 100 V ~ 240 V, 50/60 Hz	
65" Power Consumption Without OPS	180W	
75" Power Consumption Without OPS	260W	
86" Power Consumption Without OPS	380W	
Standby Condition	< 0.5W	
Speaker	2x15W	

## Front Interface

Public USB3.0	x3
Touch USB	x1
HDMI IN	x1
Type-C	x1

## Rear Interface

RJ45 IN	x1
HDMI OUT	x1
OPTICAL OUT	x1
(Mini)LINE OUT	x1
TOUCH USB	x1
HDMI IN	x1
(Mini)MIC IN	x1
Android USB 2.0	x2
Type-C	x1
RS232 UART	x1

## Network

Wired Network	Support 10/100Mbps
WiFi Standard	Built-in WiFi, support AP hotspot
WiFi Protocol	Wifi/AP : 802.11 a/b/g/n/ac/ax
WiFi Working Frequency	2.4G&5G
WiFi Working Distance	0~12m

## Bluetooth

Standard	Built-in
Version	2.1+EDR/3.0/4.x/5.2/5.3/5.4
Working Frequency	2.4GHz
Working Distance	0~12m



## Camera(Optional)

Quantity	1
Pixel	13MP/48MP
Position	Middle Top
Field of vision	120°
Resolution	Support 4K (under Windows)

## Microphone(Optional)

Quantity	8
Pick-up Distance	0-8m
View Angle	0°~180°

## Touch Parameter

Touch Type	Infrared Touch Frame
Surface Protection	3.2mm toughened glass
Infrared Touch	20 Points(Standard)
Interpolation Resolution	32768 x32768
Response Time	≤8ms
Input Mode	Finger or Pen
Theory Clicks	Unlimited
Interface method	USB+UART

## Structure Parameter

Model Num	GSTL-X9-65S	GSTL-X9-75S	GSTL-X9-86S
Size	65inch	75inch	86inch
Product Size(L x H x D)	1483.8x886.9x115.8mm	1706x1012x116mm	1953.2x1152.2x115mm
Package Size(L x H x D)	1615.8x1012x220mm	1838x1138x220mm	2086x1276x220mm
Housing Material(Face frame/rear shell)	Aluminum/Metal Plate	Aluminum/Metal Plate	Aluminum/Metal Plate
Shell color (Face frame/rear shell)	Grey/Black	Grey/Black	Grey/Black
VESA	4-M8 Screw Hole 600mmx400mm	4-M8 Screw Hole 800mmx400mm	4-M8 Screw Hole 800mmx600mm
Net Weight	36±1KG	49±1KG	58±1KG
Gross Weight	47±1KG	60±1KG	79±1KG

## Accessory

Remote Control	x1
Touch Pen	x1
Power Cord	x1
HDMI Cable (Optional )	x1
TOUCH USB Cable(Optional )	x1
E-User's Manual	x1
Wall Mount	x1
Mobile Stand(Optional)	x1

## Environment

Working Temperature	0℃~40℃
Working Humidity	10%~80%RH
Storage Temperature	-20℃~60℃
Storage Humidity	10%~90%RH
Working Altitude	Below 5000 meters

## Warranty

Warranty Time	1 Years
---------------	---------

## Disclaimer

1. Due to the influence of many aspects such as configuration and manufacturing process, the actual size/weight of this product may vary. The specification is for reference only, please refer to the actual situation.
2. The product pictures attached to this specification are only for illustrative display, the actual effect (including but not limited to appearance, color, size) may be slightly different, please refer to the actual product.
3. The packaging materials for this product are designed in strict accordance with the storage conditions of this product.
4. Abnormalities caused by extreme weather and long storage time cannot be guaranteed to be completely avoided. Please be informed.
5. Please store in strict accordance with the required storage conditions. Improper storage may cause abnormalities.
6. In case of any situation involving the above modification and update, no prior notice will be given.

**Product View-GSTL-X9-65S**

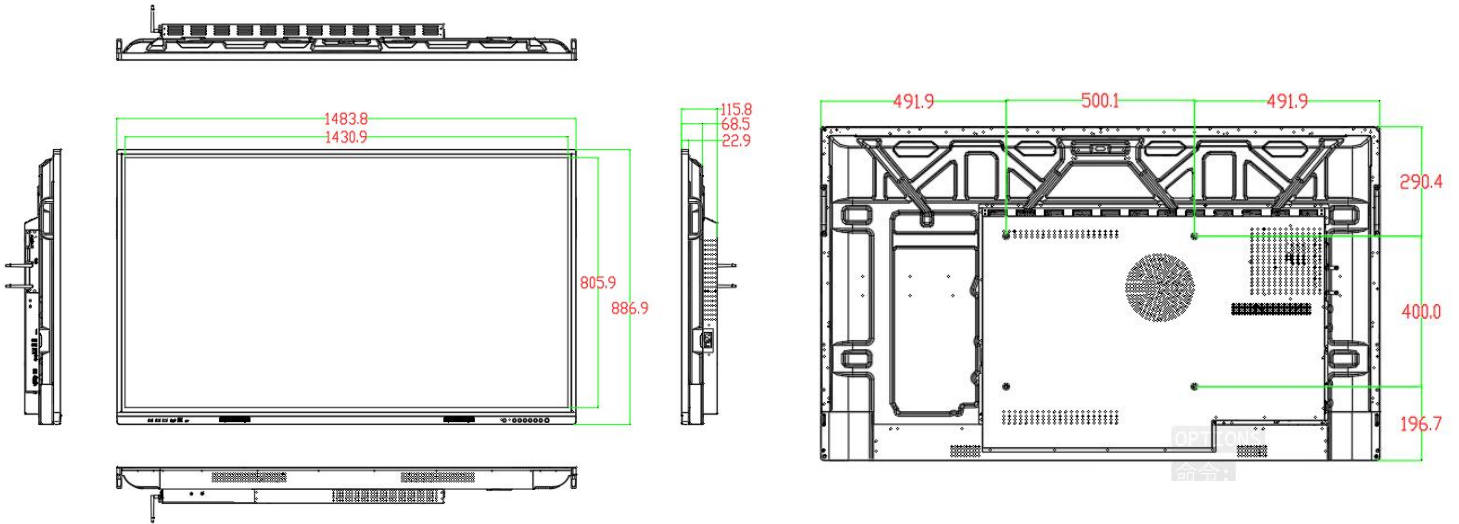

**Product View-GSTL-X9-75S**

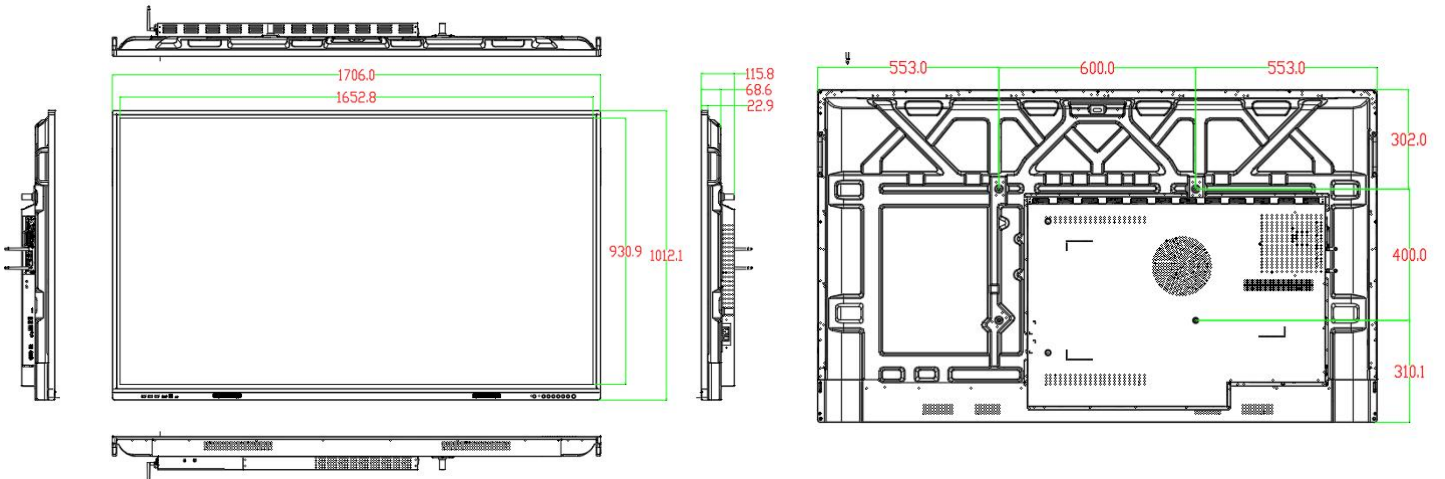

**Product View-GSTL-X9**

